

Autonomous Mobile Robots LD Series

Designed to automate material transport tasks in factories and indoor facilities.



- Natural-feature navigation:
Automatically plans efficient routes and prevents collisions
- Fleet management:
Supervises and coordinates the entire fleet of up to 100 vehicles
- Easy deployment:
Short installation time, no facility modifications



Ordering Information

Appearance	Product Name	Maximum Load	Maximum Speed	Configuration		Part Number
	LD-60	60 kg	1.8 m/s	Standard	---	37032-00000
				Docking station kit	Docking station Battery power cable	37032-00002
				Starter kit	Docking station Battery power cable Joystick, Top plate	37032-10004
	LD-60 ESD*			Standard	---	37032-20000
				Docking station kit	Docking station Battery power cable	37032-20002
				Starter kit	Docking station Battery power cable Joystick, Top plate	37032-20004
	LD-90	90 kg	1.35 m/s	Standard	---	37042-00000
				Docking station kit	Docking station Battery power cable	37042-00002
				Starter kit	Docking station Battery power cable Joystick, Top plate	37042-10004
	LD-90 ESD*			Standard	---	37042-20000
				Docking station kit	Docking station Battery power cable	37042-20002
				Starter kit	Docking station Battery power cable Joystick, Top plate	37042-20004
	LD-250	250 kg	1.2 m/s	Standard	---	37222-00000
				Docking station kit	Docking station Battery power cable	37222-00002
				Starter kit	Docking station Battery power cable Joystick, Top plate	37222-10004
	LD-250 ESD*			Standard	---	37222-20000
				Docking station kit	Docking station Battery power cable	37222-20002
				Starter kit	Docking station Battery power cable Joystick, Top plate	37222-20004

LD Series

Appearance	Product Name	Maximum Load	Maximum Speed	Configuration		Part Number
	LD-105 CT (Cart Transporter)	105 kg	1.35 m/s	Standard	Touchscreen Side laser	37142-00010
				Docking station kit	Touchscreen Side laser Docking station Battery power cable	37142-00012
				Starter kit	Touchscreen Side laser Docking station Battery power cable Acuity Localization Joystick Cart	37142-01014
	LD-130 CT (Cart Transporter)	130 kg	0.9 m/s	Standard	Touchscreen Side laser	37162-00010
				Docking station kit	Touchscreen Side laser Docking station Battery power cable	37162-00012
				Starter kit	Touchscreen Side laser Docking station Battery power cable Acuity Localization Joystick Cart	37162-01014

* For use in electrostatic-sensitive environments, compliant to the IEC 61340-5-1 standard.

Note: To ensure proper fleet management, please contact an OMRON representative before ordering AMRs to add to an existing fleet.

Note: Batteries are sold separately. Refer to *Accessories* on page 3 for more information.

Fleet Operations Workspace Solutions







Product Name	Configuration	Part Number
Primary Fleet Operations Workspace (FLOW) Core License, 1 Year	Entitlement for a 1 year renewable Primary FLOW Core license, runtime and development, per AMR connection	20271-800
Primary Fleet Operations Workspace (FLOW) Core License, 5 Year	Entitlement for a 5 year renewable Primary FLOW Core license, runtime and development, per AMR connection	20271-806
Secondary Fleet Operations Workspace (FLOW) Core License, 1 Year	Entitlement for a 1 year renewable Secondary FLOW Core license per fleet, redundant runtime	20271-802
Secondary Fleet Operations Workspace (FLOW) Core License, 5 Year	Entitlement for a 1 year renewable Secondary FLOW Core license per fleet, redundant runtime	20271-807
Primary Fleet Manager	EM2100 appliance with Temporary 120 Day Fleet Operations Workspace license	20271-900
Secondary Fleet Manager	EM2100 appliance with Temporary 120 Day Fleet Operations Workspace license	20271-901
Bundle, Fleet Simulator	EM2100 appliance with entitlement for perpetual Fleet Simulator license	20271-903
License, Fleet Simulator	Entitlement for perpetual Fleet Simulator license for use with existing EM2100 appliance, simulation runtime and development	20271-804
Fleet Operations Workspace iQ, 1 Year License	Entitlement for a 1 year renewable FLOW iQ license	20271-701
Fleet Operations Workspace iQ, 5 Year License	Entitlement for a 5 year renewable FLOW iQ license	20271-705

* To obtain the latest version of the Fleet Operations Workspace (FLOW) Core software, contact your local OMRON representative. An active subscription is required for access to software upgrades.

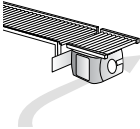

* Expiration of a 1 year subscription license without renewal will result in cessation of the fleet management functions of the OMRON AMR solution until the license is renewed.

* After four consecutive 1 year renewals (for a total of 5 years) or after purchase of a 5 year license, all fleet management functions will continue to operate without requiring subsequent subscription renewals. An active subscription will still be required to have access to subsequent software releases, including bug fixes, feature upgrades and performance improvements.





Options

Appearance	Product Name	Details	Part Number
	High Accuracy Positioning System (HAPS) Single sensor	<ul style="list-style-type: none"> • One Sensor • One mounting bracket • One power connector • One RS-232 connector • Magnetic tape 	LD-60/90: 13660-100 LD-250: 21374-100
	High Accuracy Positioning System (HAPS) Double sensor	<ul style="list-style-type: none"> • Two Sensors • Two mounting brackets • Two power connectors • Two RS-232 connectors • Magnetic tape 	LD-60/90: 13660-000 LD-250: 21374-000
	Magnetic tape	25 mm wide magnetic tape (South top side, 45.7 m roll)	14925-000
	Cell Alignment Positioning System (CAPS)	Software license activated on each AMR individually.	20271-805
	Acuity Localization	Camera, mounting kit, cables, leveling kit	13700-000
	Touchscreen	<ul style="list-style-type: none"> • Touchscreen, 7 inch, with bracket • Power supply with bracket • Power cable from core to power supply • Power cable from power supply to touchscreen • Ethernet cable between touchscreen and core • Software package including touchscreen support 	13605-000
	Side Laser Bundle	<ul style="list-style-type: none"> • Two Lasers • One cable 	13456-000
	Side Laser Kit	<ul style="list-style-type: none"> • Two Lasers • One cable • Two mounting kits • Two metal covers 	13456-100
	Call/Door Box	Provides functions to summon an AMR or open a door with wired or wireless communications.	13029-802
	EM2100 Appliance	Appliance that runs any of the Fleet Operations Workspace Solutions software. Refer <i>Fleet Operations Workspace Solutions</i> on page 2 for more information.	20271-900 (Primary Fleet Manager) 20271-901 (Secondary Fleet Manager) 20271-903 (Bundle, Fleet Simulator)

Accessories

Appearance	Product Name	Details	Part Number
	Battery	Removable and rechargeable power source for the AMR. Batteries must be purchased separately.	20452-000
	Docking Station	Used to autonomously charge the battery inside an AMR or to charge an AMR battery outside of the AMR with a supplied cable.	12477-000F (LD-60, LD-90, LD-250) 12477-050F (LD-105 CT, LD-130 CT)
	Joystick	Handheld device for manually driving an AMR and map creation. 3 m cable length.	13558-000

LD Series

Appearance	Product Name	Details	Part Number
	Breakout Cable	DB44HD breakout cable (D-Sub44 pin cable for digital I/O interface)	14165-000
	Top Plate - LD-60, LD-90	Not required for building a customer payload structure.	12944-000
	Top Plate - LD-250 Top Plate - LD-250 ESD	Not required for building a customer payload structure.	20458-002 20458-202
	Cart	Attaches to LD CT AMRs to increase payload capacity.	75020-000
	Battery Power Cable	Cable length: 0.45 m	12676-000L

Specifications

LD-60, LD-90, LD-60 ESD, LD-90 ESD, LD-105 CT (Cart Transporter) and LD-130 CT (Cart Transporter)

Item		LD-60	LD-90	LD-105 CT	LD-130 CT
Weight (with Battery)		62 kg		81 kg (AMR)/23 kg (Cart)	
Environment	Ambient temperature	5 to 40°C			
	Ambient humidity	5 to 95% (non-condensing)			
	Operating Environment	Indoor usage only, no excessive dust, no corrosive gas. Floor must be free of water, oil, dirt, and debris. Direct sunlight may cause safety laser false positives.			
	Ingress Protection Class	IP20			
Cleanroom rating		Fed Class 100, ISO Class 5		None	
Floor Conditions	Minimum floor flatness	F ₂₅ (ACI 117 standard)			
	Traversable step	15 mm max.* ¹	10 mm max.* ¹	5 mm max.* ²	5 mm max.* ²
	Traversable gap	15 mm max.	15 mm max.	5 mm max.* ²	5 mm max.* ²
	Climb grade	Up to 60 kg: 1:12 or less Over 60 kg: Level floor only		Level floor only	
Navigation	Routing	Autonomous routing by localizing with safety scanning laser based on environment mapping			
	Environmental map making method	Scan by walking the AMR through the environment, and upload the scan data to the MobilePlanner software			
Payload	Maximum Weight, excluding cart weight for CT	60 kg	90 kg	105 kg	130 kg
Mobility	Maximum Speed	1800 mm/s	1350 mm/s	1350 mm/s	900 mm/s
	Maximum Rotation Speed	180 °/s	180 °/s	100 °/s	
	Stop Position Repeatability (single AMR)	<ul style="list-style-type: none"> To a position: ±65 mm To standard target: ±25 mm, ±2° With CAPS: ±8 mm, ±0.5° With HAPS: ±8 mm, ±0.4° 			
	Stop Position Repeatability (Fleet)	<ul style="list-style-type: none"> To a position: ±85 mm To standard target: ±35 mm, ±2° With CAPS: ±12 mm, ±0.5° With HAPS: ±10 mm, ±0.5° 			
Drive wheels	Materials	Non-marking nylon foam-filled rubber, non-conductive			
Passive casters	Materials	Conductive thermoplastic rubber on polyolefin			
Auxiliary Power		5 VDC±5%, 1 A switched Aux power 12 VDC±5%, 1 A switched Aux power 20 VDC±5%, 1 A switched Aux power 22 to 30 VDC, 4 A switched × 2 22 to 30 VDC, 10 A switched 22 to 30 VDC, 10 A safe, switched 10 A switched and 10 A safe, switched are from the same source and pass through the same 10 A fuse, so the sum of their current must be less than 10 A.			

Item		LD-60	LD-90	LD-105 CT	LD-130 CT
Standard	Harmonized Standard	EN ISO 12100 / EN ISO 13849-1 / EN 60204-1			
	Relevant Standard	EN 1525 / ANSI B56.5			
	Wireless	802.11 a/b/g/n/ac			
Safety Features	Safety Scanning Laser	One at front of AMR Class 1 PLd safety per ISO13849-1 240° field of view			
	E-STOP Buttons	One at Operator Panel		One at HMI post touchscreen, one at Operator Panel	
	Back Sonar	Two at back, 2 m range Each pair includes one emitter and one receiver working together			
	Front Bumper	One at front of AMR, two pairs of sensors			
	Low Front Laser	One at front of AMR Class 1 4 m maximum range 126° field of view			
	Side Laser	Option: Two on sides of payload structure, user-mounted Class 1 4 m maximum range 270° field of view		Two on horizontal tubes of HMI post Class 1 4 m maximum range 270° field of view	
	Rear Laser	Not available		One on HMI post	
	Visual Indicators	Light discs are located on the sides of the AMR. Additional indicators can be added.		Light disk on each side, beacon on HMI post. Additional indicators can be added.	
	Audible Indicators	Two speakers are included. Additional buzzers can be added.			
Operator Interface	Display / Touch Screen	3.5 inch, 320 × 240 pixels, color		7.0 inch, 800 × 480 pixels, touch screen, color	
	Button	ON button: green OFF button: red Brake-release button: orange Keyswitch		ON button: green OFF button: red Brake-release button: orange Keyswitch Latch button, unlatch button	
User Interface	Wireless	802.11 a/b/g/n/ac			
	Ethernet Port	One user LAN, One maintenance LAN, Auto-MDIX			
	Serial	Two RS-232			
	Digital I/O	16 inputs, 16 outputs			
	Analog I/O	8 inputs (0 to 30 V), 4 outputs (0 to 20 V)			
	Audio	Digital audio out, audio in / audio out			
Cart Latching	Latching Method	Not available		Automatic	

*1 A speed of 250 to 300 mm/s and 250 mm/s, for the LD-60 and LD-90, is required for these steps. Faster or frequent driving over such steps or gaps will shorten the lifespan of the drivetrain components. Lower speeds may not traverse the step. Steps should have smooth, rounded profiles.

*2 The LD-105 CT and LD-130 CT (Cart Transporters) with a cart is capable of driving over a gap or step of 5 mm at a speed of 250 mm/s, but this should not be regarded as normal use. Regular driving over such gaps or steps will shorten the lifespan of the drivetrain components.

LD-250, LD-250 ESD Specifications

Item		LD-250
Weight		148 kg (with battery), 129 kg (without battery)
Environment	Ambient temperature	5 to 40°C
	Ambient humidity	5 to 95% (non-condensing)
	Operating Environment	Indoor usage only, no excessive dust, no corrosive gas. Direct sunlight may cause safety laser false positives.
	Ingress Protection Class	IP20
	Cleanroom rating	Fed Class 100, ISO Class 5
Floor Conditions	Floor Condition	No water, no oil, no dirt
	Minimum floor flatness	F _r 25 (ACI 117 standard)
	Traversable step	10 mm max. The LD-250 should traverse a step at 600 mm/s or slower for best performance of the laser and battery.
	Traversable gap	15 mm max.
	Climb grade	Level floor only (full payload)
Navigation	Routing	Autonomous routing by localizing with safety scanning laser based on environment mapping
	Environmental map making method	Scan by manually driving the AMR through the environment, and upload the scan data to the MobilePlanner for map creation.

LD Series

Item		LD-250
Payload	Maximum Weight	250 kg
Mobility	Maximum Speed	1200 mm/s
	Maximum Rotation Speed	120 °/s
	Stop Position Repeatability (single AMR)	<ul style="list-style-type: none"> To a position: ±75 mm To standard target: ±25 mm, ±2° With CAPS: ±8 mm, ±0.5° With HAPS: ±8 mm, ±0.4°
	Stop Position Repeatability (Fleet)	<ul style="list-style-type: none"> To a position: ±100 mm To standard target: ±35 mm, ±2° With CAPS: ±14 mm, ±0.6° With HAPS: ±10 mm, ±0.6°
Drive wheel	Materials	Aluminum with polyurethane tread
Passive caster	Materials	Elastomer (Polyurethane)
Auxiliary Power		5 VDC±5%, 1 A switched Aux power 12 VDC±5%, 1 A switched Aux power 20 VDC±5%, 1 A switched Aux power 22 to 30 VDC, 4 A switched × 2 22 to 30 VDC, 10 A switched 22 to 30 VDC, 10 A safe, switched 10 A switched and 10 A safe, switched are drawn from the same source, and pass through the same 10 A fuse, so the sum of their current must be less than 10 A.
Standards	Harmonized Standard	EN ISO 12100 / EN ISO 13849-1 / EN 60204-1
	Relevant Standard	EN 1525 / ANSI B56.5
	Wireless	802.11 a/b/g/n/ac
Safety Features	Safety Scanning Laser	One at front of AMR Class 1 PLd safety per ISO13849-1 240° field of view
	E-STOP Buttons	One at Operator Panel, one on each side (three total)
	Rear Sensing	Time of flight (TOF) sensors
	Low Front Laser	One at front of AMR Class 1 4 m maximum range 126° field of view
	Side Laser	Option (Two on sides of payload structure, user-mounted)
	Visual Indicators	Light discs are located on the sides of the AMR. Additional indicators can be added.
	Audible Indicators	Two speakers are included. Additional buzzers can be added.
Operator Interface	Display	3.5 inch TFT 320 × 240 pixels, color screen
	Touch Screen	Option, 7.0 inch, 800 × 480 pixels, color
	Button	ON button: green OFF button: red Brake-release button: orange Keypad (disabled OFF button)*
User Interface	Wireless	802.11 a/b/g/n/ac
	Ethernet Port	One user LAN, One maintenance LAN, Auto-MDIX
	Serial	Two RS-232
	Digital I/O	16 inputs, 16 outputs
	Analog I/O	8 inputs (0 to 30 V), 4 outputs (0 to 20 V)
	Audio	Digital audio out, audio in / audio out
Cart Latching		Not available

MobilePlanner Software

CPU	1.5 GHz dual-core CPU recommended
Main Memory	1.5 GB min. (4 GB min. recommended)
Hard Disk	At least 200 MB of available space
Video Memory	256 MB min.
Display	XGA 1024 × 768, 16 million colors
Supported Languages	English, Japanese, German, French, Italian, Korean, Spanish, Polish, Simplified Chinese, Traditional Chinese

Touchscreen

Touch Panel	PCAP touch sensor, black-bordered cover lens
TFT Display	TFT LCD panel, 18/24 bit RGB parallel interface, 7.0 inch WVGA - wide viewing angles, 5-touch
Backlight	Constant current LED supply
Power Input	5 VDC supplied through power connector
Power Consumption	6.5 W maximum

LD Series

EM2100 Appliance

Weight	9.1 kg
Mounting method	1U rack mount in a standard 19-inch equipment rack
Power Supply	100 to 240 VAC (typical 100 W)
Power Consumption	200 W max.
Operating Temperature	10 to 35°C
Storage Temperature	-25 to 60°C
Operating Humidity	8 to 90%, non-condensing
Storage Humidity	5 to 95%, non-condensing
Chassis Ingress Protection Class	IP20
CPU	Intel® Xeon® CPU
Main Memory	32 GB DDR3
Storage	60 GB SSD
Archive Storage	4 TB HDD
Communication ports	Four 10/100/1000 Ethernet Four USB One VGA
Status Display	Multi-segment LCD

High Accuracy Positioning System

Sensor	Depth	30 mm
	Width	160 mm
	Ingress Protection Class	IP64
	Environment	-40 to 85°C
Magnetic Tape	Width	25 mm
	Orientation	South up
Markers (Magnetic Tape)	Width	25 mm
	Length	300 mm min. for 500 mm/s drive speed
	Orientation	North up
	Separation From Tape	15 to 30 mm
Connections	Front Sensor	RS232-1 (/dev/ttyUSB9) on the core
	Rear Sensor	RS232-2 (/dev/ttyUSB10) on the core
	Power, Both Sensors	Aux power using the included splitter cable
Stop Position Repeatability, LD-60, LD-90	Single AMR	±8 mm position, 0.4° rotation
	Fleet	±10 mm position, 0.5° rotation
Stop Position Repeatability, LD-250	Single AMR	±8 mm position, 0.4° rotation
	Fleet	±10 mm position, 0.6° rotation

Cell Alignment Positioning System (CAPS)

Stop Position Repeatability, LD-60, LD-90	Single AMR	±8 mm position, 0.5° rotation
	Fleet	±12 mm position, 0.5° rotation
Stop Position Repeatability, LD-250	Single AMR	±8 mm position, 0.5° rotation
	Fleet	±14 mm position, 0.6° rotation
Type	Software license	

Call/Door Box

Weight	190 g
Mounting method	Mount to the provided wall frame with four screws
Power Supply	12 VDC
Power Consumption	0.5 A, 6 W typical
Wireless	IEEE 802.11 a/b/g/n
Communication Port	Ethernet
I/O	Two Inputs
	Two Outputs (30 VDC, 2 A max.)

Battery

Run Time (No Payload)	15 h approx. (LD-60, LD-90) 13 h approx. (LD-250)
Weight	19 kg
Voltage	22 to 30 VDC
Capacity	72 Ah (battery cell nominal)
Recharge Time	4 h approx.
Life Expectancy	2,000 times 80% DOD (battery cell nominal), 7 years, approx., 16 h/day, 5 days/week 4 years, approx., 19/7 (full-time)
Charging Method	Automatic or manual

Docking Station

Current	8 A*1
Power	100 to 240 VAC, 50 to 60 Hz
Power Consumption	800 W
Humidity	5 to 95%, non-condensing
Temperature	5 to 40° C
Dimensions (W × D × H)	349 × 369 × 315 mm 495 × 495.5 × 317 mm (with floor plate)
Weight	8.2 kg
Mounting	Wall bracket, directly to floor, or on floor with floor plate
Indicators	Power on: blue Charging: yellow
Connector	For out-of-AMR battery charging

*1 Circuit breaker built into AC power switch

Joystick

Weight	0.55 kg
IP Rating	IP56

Acuity Localization

Field of View	140°
Power Input	12 VDC (±10%) supplied from AMR through power connector
Power Consumption	3.3 W maximum

Cart

Weight	23 kg
Rating	ESD-rated
Passive Casters	Two front, Two rear, spring-loaded
Caster Diameter	100 mm nominal
Caster Brakes	On two rear casters

LD Series

System Configuration

LD-60/90 and LD-250

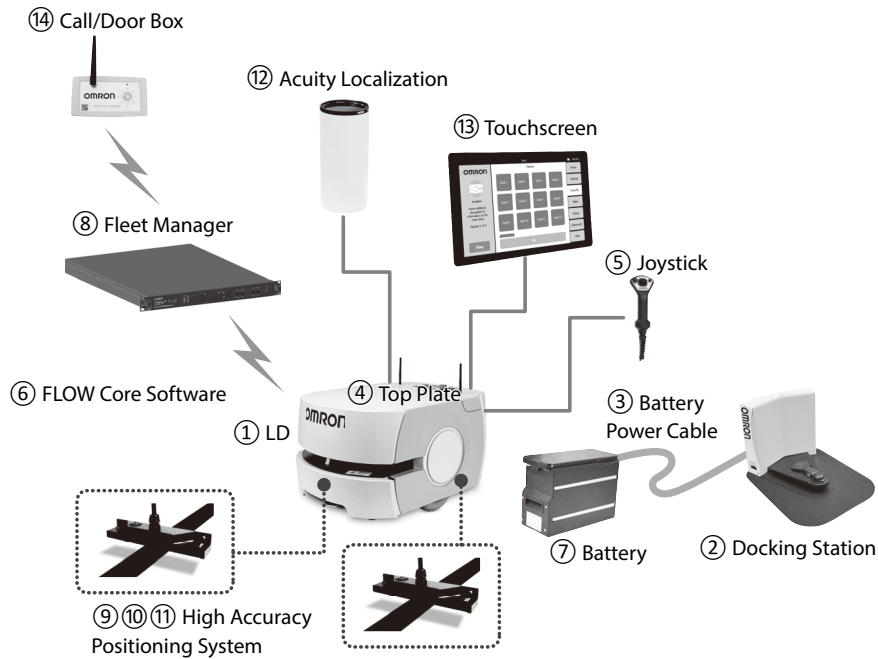

	Product Name	Part Number	Description	Notes
①	LD	37□□2-00000	An AMR LD running the FLOW Core Software.	
②	Docking Station	12477-000	A docking station to charge the battery installed in the AMR.	Included in docking station kit and starter kit
③	Battery Power Cable	12676-000L	A cable to connect a battery and docking station to charge the battery outside of the AMR.	
④	Top Plate	12944-000 20458-002 20458-202	Parts listed are for LD-60/90, LD-250, and LD-250 ESD. There is no unique LD-60/90 ESD top plate.	A top plate is not necessary for building a customer payload structure. Included in starter kit
⑤	Joystick	13558-000	Used for manually controlling the AMR.	
⑥	FLOW Core Software	Embedded	The OMRON mobile solution operating software supporting navigation, safety, fleet management and advanced features.	---
⑦	Battery	20452-000	A battery that is installed in the AMR.	The battery must be purchased separately for the LD.
⑧	Fleet Manager	20271-900	EM2100 appliance with FLOW Core software configured for AMR fleet management.	---
⑨	High Accuracy Positioning System (Single sensor)	13660-100 21374-100	A combination of sensor and magnetic tape to achieve accurate alignment during forward driving motion, when the sensor is attached to AMR and magnetic tape is on the floor.	13660-□00 are for LD-60/90 21374-□00 are for LD-250.
⑩	High Accuracy Positioning System (Double sensor)	13660-000 21374-000	A combination of two sensors and magnetic tape to achieve accurate alignment during forward and backward driving motions, when the sensors are attached to AMR and magnetic tape is on the floor.	
⑪	Magnetic Tape*	14925-000	Magnetic tape for the High Accuracy Positioning System, applied to the floor to signal the AMR where to stop.	Not shown in figure. Comes with each HAPS system.
⑫	Acuity Localization	13700-000	Used where process layout or obstacle location changes often. Installed on a payload structure attached to the AMR.	---
⑬	Touchscreen	13605-000	Allows operators to check the status of the AMR, enter goals, and pause the AMR. Installed on a payload structure attached to the AMR.	---
⑭	Call/Door Box	13029-802	Used to issue a request for a AMR to go to the goal or to open a closed door. Usually installed at location of use.	---
	Side Laser Bundle	13456-000	Used to detect obstacles that are at heights that the safety scanning laser cannot detect. Installs on a payload structure attached to the AMR.	Not shown in diagram
	Side Laser Kit	13456-100	Includes the side lasers, mounting kit, and metal enclosures.	
	Breakout Cable	14165-000	A D-Sub 44 pin cable for digital I/O interface of the AMR.	

*A protective covering needs to be installed when applying the magnetic tape to the floor to prevent damage from the AMR traffic. OMRON does not provide the protective covering with the HAPS option. The protective covering must be supplied by the user.

Components and Functions

LD-60, LD-90, LD-60/90 ESD

Operator Panel

Power ON/OFF, E-STOP, brake button, 3.5-inch color monitor.

Wireless Antenna

IEEE 802.11 a/b/g.

Back Sonar

Detect obstacles in back of AMR using sonar.

Top Plate (Option)

Top plate comes with Starter Kit. Not required when building customer payload.

Safety Scanning Laser

Safety-rated laser used for simultaneous localization and safety functionality.



Light Discs

Status indicator is located on both sides.

Front Bumper

Stops when makes contact with obstacle.

Low Front Laser

Obstacle sensor detects low-profile objects when moving forward.

LD-250, LD-250 ESD

Operator Panel

Power ON/OFF, E-STOP, brake button, 3.5-inch color monitor.

Wireless Antenna

IEEE 802.11 a/b/g.

Rear Sensors

Detect rear obstacles using time of flight (TOF) sensors.

Top Plate (Option)

Top plate comes with Starter Kit. Not required when building customer payload.



E-STOP Button

One on each side of AMR.

Safety Scanning Laser

Safety-rated laser used for simultaneous localization and safety functionality.

Light Discs

Status indicator is located on both sides.

Low Front Laser

Obstacle sensor detects low-profile objects when moving forward.

LD Series

Components and Functions

LD-105 CT (Cart Transporter) and LD-130 CD (Cart Transporter)

Operator Panel

- 7 inch color touchscreen (status, goal input)
- Wireless antenna × 2
- E-STOP
- Power ON/OFF
- Brake Button
- Latch/unlatch buttons for cart
- Beacon
- Acuity Localization (option)



Rear Laser
Rear obstacle detection laser.

Side Laser (1 of 2)
Vertical-scan obstacle detection laser.

Cart
Automatically latches/unlatches cart, Latching/unlatching can be controlled by software.

Manual Brake Release Cable. User-mounted.

LD with cart latching plate.

The cart comes with a manual brake release. The user decides where on the cart or its payload structure to mount the manual brake release lever.

System Configuration

LD-105 CT and LD-130 CD (Cart Transporters)

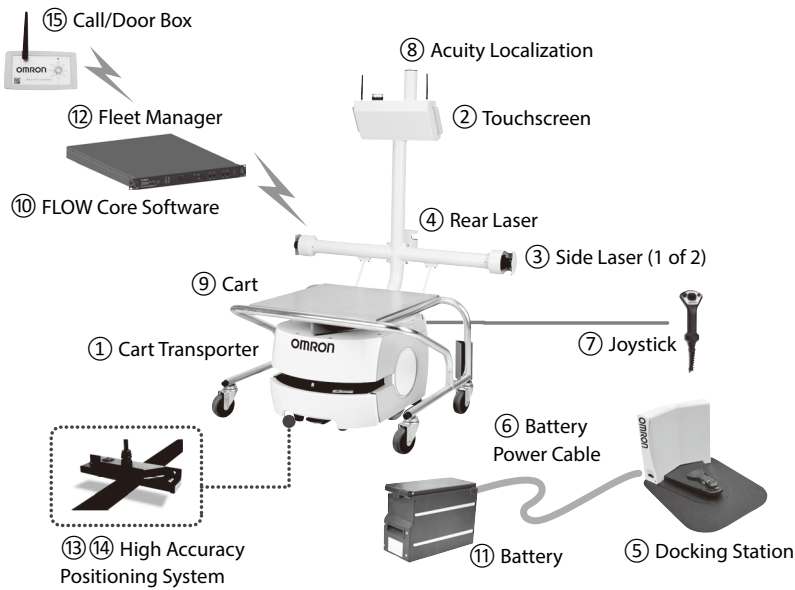

	Product Name	Part Number	Description	Notes
①	Cart Transporter	371□2-00000	An LD-105 CD or LD-130 CT (Cart Transporter) running the FLOW Core Software.	
②	Touchscreen	13605-000	Allows operators to check the status of the AMR, enter goals, and pause the AMR. Installed on a payload structure attached to the AMR.	
③	Side Laser (x2)	13456-000	Used to detect obstacles that are at heights the safety scanning laser of the AMR cannot detect. Installed on a payload structure attached to the AMR.	Included in docking station kit and starter kit
④	Rear Laser	13456-000	Used to detect obstacles that are behind the AMR. This is the same part number as is used for the Side Lasers.	
⑤	Docking Station	12477-050	A docking station to charge the battery installed in the AMR.	
⑥	Battery Power Cable	12676-000L	A cable to connect a battery and docking station to charge the battery outside of the AMR.	
⑦	Joystick	13558-000	Used for manually controlling the AMR.	
⑧	Acuity Localization	13700-000	Used where process layout or obstacle location changes often. Installed on a payload structure attached to the AMR.	Included in starter kit
⑨	Cart	75020-000	A cart designed to work seamlessly with the LD-105 CT or LD-130 CT (Cart Transporter).	
⑩	FLOW Core Software	Embedded	The OMRON mobile solution operating software supporting navigation, safety, fleet management and advanced features.	---
⑪	Battery	20452-000	A battery that is installed in the AMR.	The battery must be purchased separately for the LD.
⑫	Fleet Manager	20271-900	EM2100 appliance with FLOW Core software configured for AMR fleet management.	---
⑬	High Accuracy Positioning System (Single sensor)	13660-100	A sensor and magnetic tape to achieve accurate alignment when the AMR follows driving forward. The sensor is attached to the AMR.	---
⑭	High Accuracy Positioning System (Double sensor)	13660-000	A combination of two sensors and magnetic tape to achieve accurate alignment during forward and backward driving motions, when the sensors are attached to AMR and magnetic tape is on the floor.	---
	Magnetic Tape*	14925-000	Magnetic tape for the High Accuracy Positioning System applied to the floor to signal the AMR where to stop.	Not shown in diagram.
⑮	Call/Door Box	13029-802	Used to issue a request for an AMR to go to the goal or to open a closed door. Installed at the goal or door.	---
	Breakout Cable	14165-000	A D-Sub 44 pin cable for digital I/O interface of the AMR.	Not shown in diagram.

*A protective covering needs to be installed when applying the magnetic tape to the floor to prevent damage from the AMR traffic. OMRON does not provide the protective covering with the HAPS option. The protective covering must be supplied by the user.

LD Series

Dimensions

CAD data can be downloaded from https://robotics.omron.com/browse-documents/dir_id=10:

(Unit: mm)

LD-60, LD-90, LD-60 ESD, and LD-90 ESD

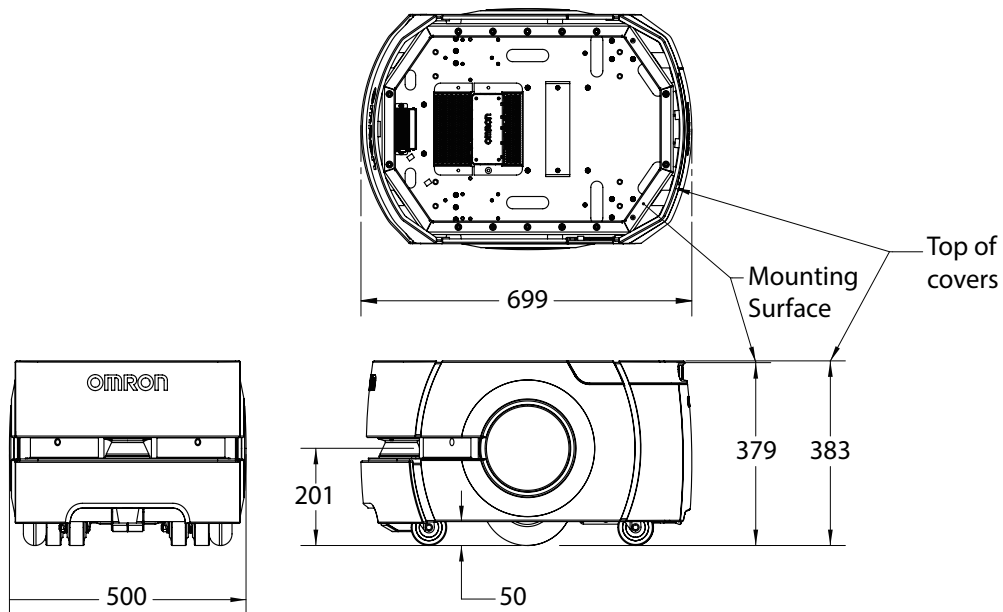

LD-250, LD-250 ESD

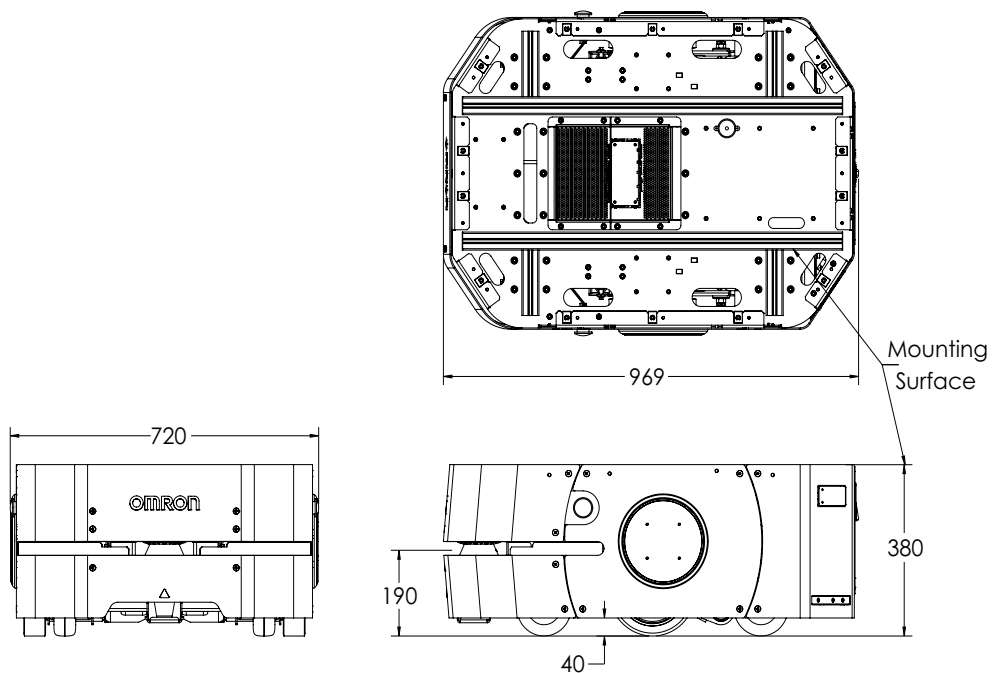

Dimensions

LD-105 CT and LD-130 CT (Cart Transporters)

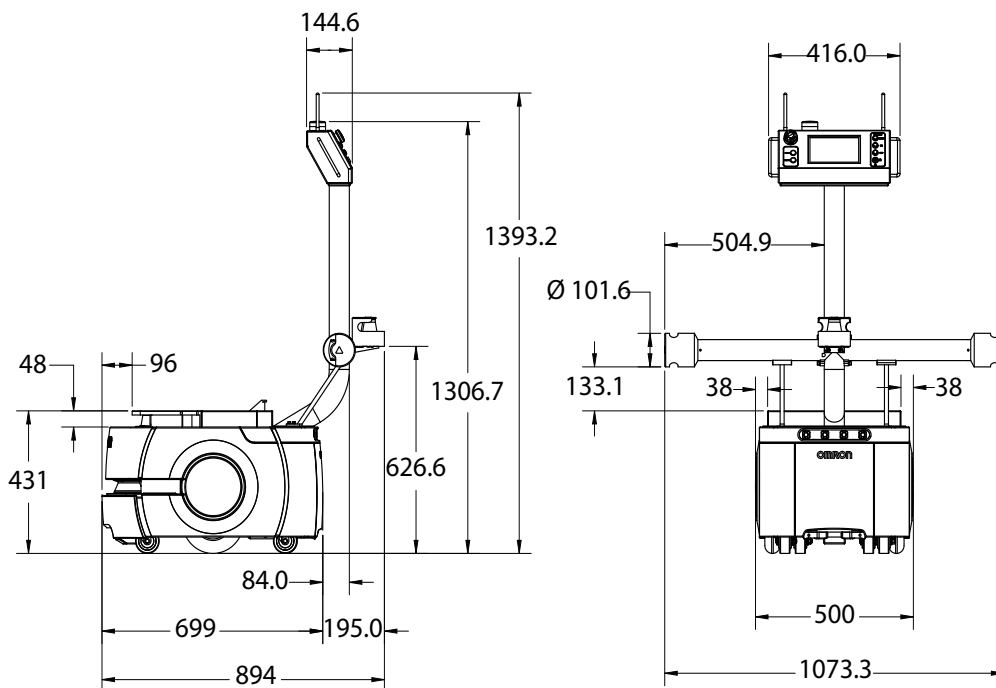

Fleet Manager EM2100 Appliance

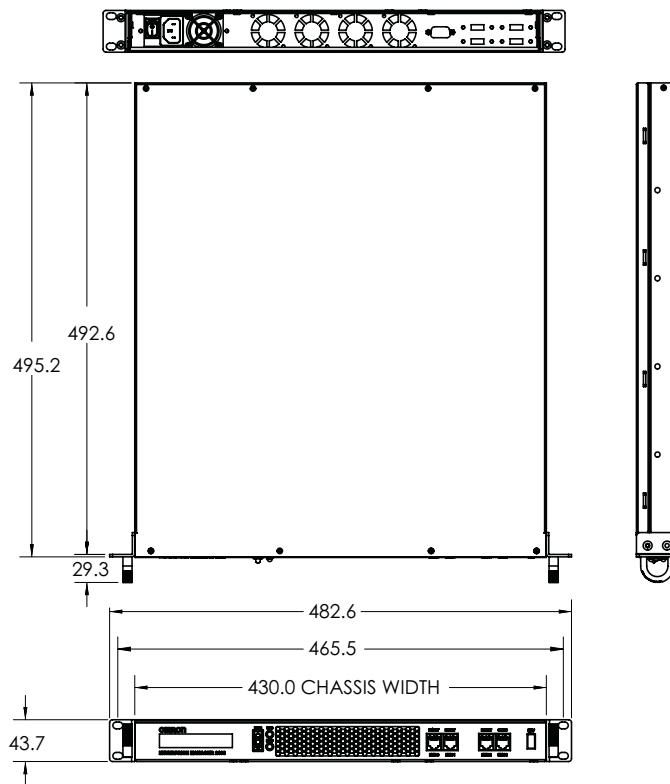

LD Series

High Accuracy Positioning System

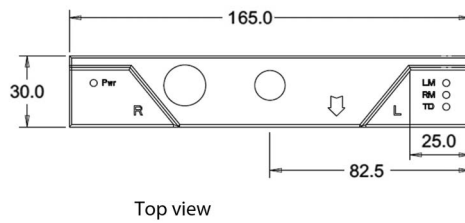
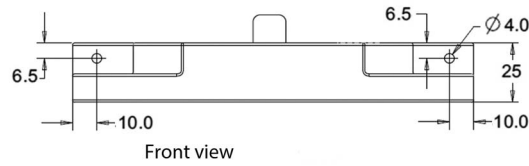

Acuity Localization

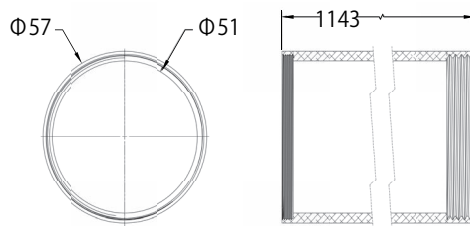

Touchscreen

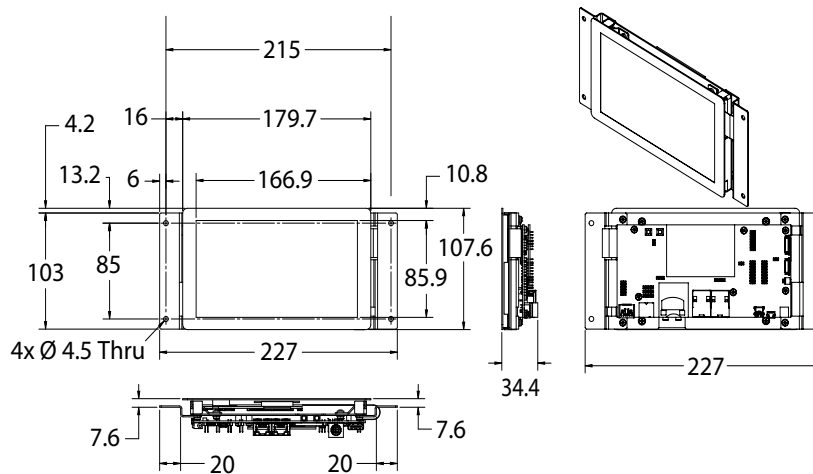

Call/Door Box

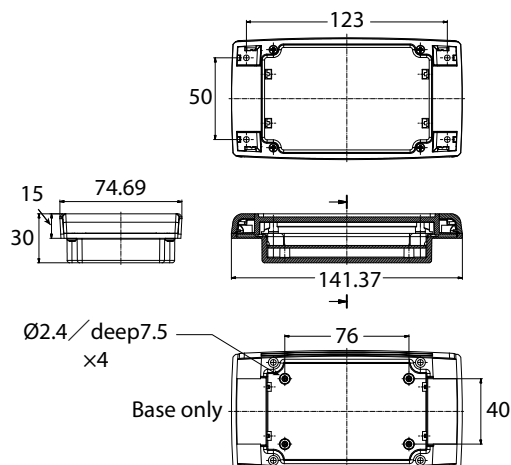

Dimensions

Docking Station

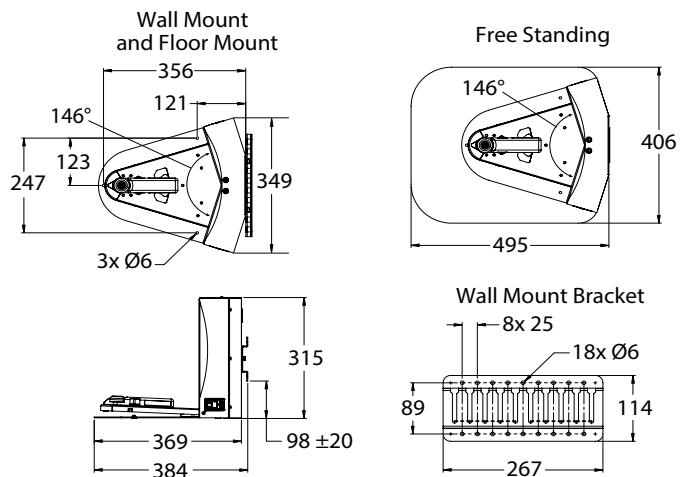

Joystick

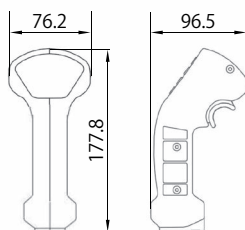

Cart

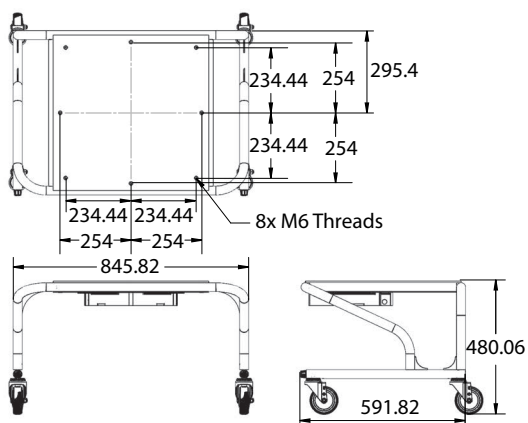

LD Series

Related Manuals

Catalog Number	Manual Title
I611	LD-60/90 Platform User's Manual
I612	Mobile Robots LD Cart Transporter User's Manual
I613	LD Platform Peripherals User's Guide
I614	Mobile Robot Software Suite User's Guide
I615	Enterprise Manager User Guide (this covers the EM1100, not the EM2100)
I616	Mobile Robot LD Safety Guide
I617	Advanced Robotics Command Language Reference Guide
I618	Advanced Robotics Command Language Fleet Manager - Mobile Robots Integration Guide
I634	EM2100 Installation Guide
I635	Fleet Operations Workspace Core User's Manual
I636	Fleet Operations Workspace Core Migration Guide
I637	Fleet Operations Workspace Core Integration Toolkit User Guide
I649	Fleet Simulator User's Manual
I642	LD-250 Platform User's Manual

- Intel, Xeon and Intel Xeon are trademarks of Intel Corporation in the U.S. and/or other countries.
- Other company names and product names in this document are the trademarks or registered trademarks of their respective companies.
- The product photographs and figures that are used in this catalog may vary somewhat from the actual products.
- Microsoft product screen shot(s) reprinted with permission from Microsoft Corporation.

Terms and Conditions Agreement

Read and understand this catalog.

Please read and understand this catalog before purchasing the products. Please consult your OMRON representative if you have any questions or comments.

Warranties.

- (a) Exclusive Warranty. Omron's exclusive warranty is that the Products will be free from defects in materials and workmanship for a period of twelve months from the date of sale by Omron (or such other period expressed in writing by Omron). Omron disclaims all other warranties, express or implied.
- (b) Limitations. OMRON MAKES NO WARRANTY OR REPRESENTATION, EXPRESS OR IMPLIED, ABOUT NON-INFRINGEMENT, MERCHANTABILITY OR FITNESS FOR A PARTICULAR PURPOSE OF THE PRODUCTS. BUYER ACKNOWLEDGES THAT IT ALONE HAS DETERMINED THAT THE PRODUCTS WILL SUITABLY MEET THE REQUIREMENTS OF THEIR INTENDED USE.

Omron further disclaims all warranties and responsibility of any type for claims or expenses based on infringement by the Products or otherwise of any intellectual property right. (c) Buyer Remedy. Omron's sole obligation hereunder shall be, at Omron's election, to (i) replace (in the form originally shipped with Buyer responsible for labor charges for removal or replacement thereof) the non-complying Product, (ii) repair the non-complying Product, or (iii) repay or credit Buyer an amount equal to the purchase price of the non-complying Product; provided that in no event shall Omron be responsible for warranty, repair, indemnity or any other claims or expenses regarding the Products unless Omron's analysis confirms that the Products were properly handled, stored, installed and maintained and not subject to contamination, abuse, misuse or inappropriate modification. Return of any Products by Buyer must be approved in writing by Omron before shipment. Omron Companies shall not be liable for the suitability or unsuitability or the results from the use of Products in combination with any electrical or electronic components, circuits, system assemblies or any other materials or substances or environments. Any advice, recommendations or information given orally or in writing, are not to be construed as an amendment or addition to the above warranty.

See <http://www.omron.com/global/> or contact your Omron representative for published information.

Limitation on Liability; Etc.

OMRON COMPANIES SHALL NOT BE LIABLE FOR SPECIAL, INDIRECT, INCIDENTAL, OR CONSEQUENTIAL DAMAGES, LOSS OF PROFITS OR PRODUCTION OR COMMERCIAL LOSS IN ANY WAY CONNECTED WITH THE PRODUCTS, WHETHER SUCH CLAIM IS BASED IN CONTRACT, WARRANTY, NEGLIGENCE OR STRICT LIABILITY.

Further, in no event shall liability of Omron Companies exceed the individual price of the Product on which liability is asserted.

Suitability of Use.

Omron Companies shall not be responsible for conformity with any standards, codes or regulations which apply to the combination of the Product in the Buyer's application or use of the Product. At Buyer's request, Omron will provide applicable third party certification documents identifying ratings and limitations of use which apply to the Product. This information by itself is not sufficient for a complete determination of the suitability of the Product in combination with the end product, machine, system, or other application or use. Buyer shall be solely responsible for determining appropriateness of the particular Product with respect to Buyer's application, product or system. Buyer shall take application responsibility in all cases.

NEVER USE THE PRODUCT FOR AN APPLICATION INVOLVING SERIOUS RISK TO LIFE OR PROPERTY OR IN LARGE QUANTITIES WITHOUT ENSURING THAT THE SYSTEM AS A WHOLE HAS BEEN DESIGNED TO ADDRESS THE RISKS, AND THAT THE OMRON PRODUCT(S) IS PROPERLY RATED AND INSTALLED FOR THE INTENDED USE WITHIN THE OVERALL EQUIPMENT OR SYSTEM.

Programmable Products.

Omron Companies shall not be responsible for the user's programming of a programmable Product, or any consequence thereof.

Performance Data.

Data presented in Omron Company websites, catalogs and other materials is provided as a guide for the user in determining suitability and does not constitute a warranty. It may represent the result of Omron's test conditions, and the user must correlate it to actual application requirements. Actual performance is subject to the Omron's Warranty and Limitations of Liability.

Change in Specifications.

Product specifications and accessories may be changed at any time based on improvements and other reasons. It is our practice to change part numbers when published ratings or features are changed, or when significant construction changes are made. However, some specifications of the Product may be changed without any notice. When in doubt, special part numbers may be assigned to fix or establish key specifications for your application. Please consult with your Omron's representative at any time to confirm actual specifications of purchased Product.

Errors and Omissions.

Information presented by Omron Companies has been checked and is believed to be accurate; however, no responsibility is assumed for clerical, typographical or proofreading errors or omissions.

Note: Do not use this document to operate the Unit.

OMRON Corporation Industrial Automation Company

Kyoto, JAPAN

Contact: www.ia.omron.com

Regional Headquarters

OMRON EUROPE B.V.

Wegalaan 67-69, 2132 JD Hoofddorp
The Netherlands
Tel: (31)2356-81-300/Fax: (31)2356-81-388

OMRON ASIA PACIFIC PTE. LTD.

No. 438A Alexandra Road # 05-05/08 (Lobby 2),
Alexandra Technopark,
Singapore 119967
Tel: (65) 6835-3011/Fax: (65) 6835-2711

OMRON ELECTRONICS LLC

2895 Greenspoint Parkway, Suite 200 Hoffman Estates,
IL 60169 U.S.A.
Tel: (1) 847-843-7900/Fax: (1) 847-843-7787

OMRON ROBOTICS AND SAFETY TECHNOLOGIES, INC.

4225 Hacienda Drive, Pleasanton, CA 94588 U.S.A.
Tel: (1) 925-245-3400/Fax: (1) 925-960-0590

OMRON (CHINA) CO., L.H.T.D.

Room 2211, Bank of China Tower, 200 Yin Cheng Zhong Road,
PuDong New Area, Shanghai, 200120, China
Tel: (86) 21-5037-2222/Fax: (86) 21-5037-2200

Authorized Distributor:

© OMRON Corporation 2021 All Rights Reserved.
In the interest of product improvement,
specifications are subject to change without notice.

Cat. No. I828-E-10

0921

11970-520 Rev. J