

Standard specifications

YF002NDE91003

November 11, 2015

KAWASAKI HEAVY INDUSTRIES, LTD.
ROBOT DIVISION

Specification :	90101-2162DEE
(Arm) :	90151-0093DEA
(Controller) :	90152-0023DEA

1. Robot Specifications

[1] Robot Arm															
1. Model	YF002N-C														
2. Type	Delta Parallel Robot														
3. Degree of freedom	4 axes														
4. Axis specification	Operating axis	Max. operating range	Max. speed												
	Arm rotation 1 (JT1)	+77 ° ~ -34.5 °	490 °/s												
	Arm rotation 2 (JT2)	+77 ° ~ -34.5 °	490 °/s												
	Arm rotation 3 (JT3)	+77 ° ~ -34.5 °	490 °/s												
	Wrist twist (JT4)	+360 ° ~ -360 °	1714.3 °/s												
5. Palletizing Capacity (Maximum)	Approx. 200 pieces/min (0.5kg weight, only robot arm) Approx. 166 pieces/min (2kg weight, only robot arm) On the condition that robot moves 25 mm stroke in up-down direction and 305 mm stroke in right-left direction. *1 Excluding picking up and placing time *2 With a limit in continuous operations														
6. Position Repeatability	±0.04mm														
7. Angular Repeatability	±0.10°														
8. Max. payload	2kg														
9. Max. liner speed	3300mm/sec														
10. Load capacity of wrist	<div style="display: flex; align-items: flex-start;"> <div style="flex: 1;"> <p style="text-align: center;">(Z)</p> </div> <div style="flex: 1;"> <table border="1" style="margin-left: auto; margin-right: auto;"> <thead> <tr> <th>load [-]</th> <th>Max Torque [Nm]</th> <th>Max Moment [Nm]</th> </tr> </thead> <tbody> <tr> <td>0.5kg</td> <td>0.13</td> <td>0.57</td> </tr> <tr> <td>1kg</td> <td>0.25</td> <td>1.15</td> </tr> <tr> <td>2kg</td> <td>0.37</td> <td>1.57</td> </tr> </tbody> </table> <p style="margin-top: 20px;">Please put the center of mass inside of the line of the each load capacity. L: Distance in X-Y dimension from Z-axis to the mass center of gravity of the load. D: Distance in Z dimension from X-Y dimension to the mass center of gravity of the load.</p> </div> </div>			load [-]	Max Torque [Nm]	Max Moment [Nm]	0.5kg	0.13	0.57	1kg	0.25	1.15	2kg	0.37	1.57
load [-]	Max Torque [Nm]	Max Moment [Nm]													
0.5kg	0.13	0.57													
1kg	0.25	1.15													
2kg	0.37	1.57													
11. Driving motor	Brushless AC Servomotor														
12. Working range	See attached drawing														
13. Mass	60 kg (without options)														
14. Color	Munsell 10GY9/1 equivalent														
15. Installation	Ceiling mounting														
16. Environment cond.	(Temperature) 10 ~ 40 °C, (Relative Humidity) 35 ~ 85 % (non-condensation)														
17. Degree of Protection	IP65 equivalent														
18. Built-in utilities	none														
19. Options															
20. Others	Consult Kawasaki about maintenance parts and spare parts.														

[2] Controller		
1. Model	E91	
2. Enclosure	Enclosed structure / Indirect cooling system	
3. Dimensions	See attached drawing	
4. Number of controlled axes	Max.6 axes	
5. Servo control and drive system	Full Digital Servo System	
6. Type of control	Teach mode	Joint, Base, Tool, Fixed Tool (option) operation mode
	Repeat mode	PTP, CP control mode Joint, Linear, Circular (option) interpolation
7. Teaching method	Teaching or AS language programming	
8. Memory capacity	8 MB	
9. External operation signals	External Motor Power Off, External Hold, etc.	
10. General purpose signals	Input signals	32 channels (Includes dedicated signals)
	Output signals	32 channels (Includes dedicated signals)
11. Operation panel	FastCheck/Teach/Repeat SW, Emergency Stop SW, Control power lamp	
12. Cable length	Power/Signal cable	10 m
	Teach Pendant cable	10 m
13. Mass	See attached drawing	
14. Power requirement	AC200 V - AC230 V±10%, 50/60 Hz, 1 phase, Max. 4 kVA	
15. Ground	Less than 100 Ω (robot dedicated ground) Leakage current: max. 100 mA	
16. Ambient temperature	0 - 40°C	
17. Relative humidity	35 - 85 % (non-condensation)	
18. Surface Treatment	Munsell: 10GY9/1	
19. Teach Pendant	TFT color display (5.7 inch LCD) with touch panel Emergency Stop SW, Teach Lock SW and Enable SW	
20. Safety Circuit	Category: 3, Performance Level: d (EN ISO13849-1: 2008) ★	
21. Options		
General purpose signals	Input signals	64/96 channels
	Output signals	64/96 channels
I/O connector	D-SUB 37pin(male,female) with cover	
Power/Signal cable	5m, 15m	
Teach Pendant cable	5m, 15m	
Motor brake release	Manual brake release switch BOX	
Auxiliary storage	USB memory	
PC cable	1.5 m, 3 m	
Teach Pendant option	Connector for TP less	
Others	Field BUS, Software PLC, Analog input/output, Conveyor Synchronization, Vision and so on	
22. Others	Consult Kawasaki about maintenance parts and spare parts.	

★ Category and Performance level (PL) are determined by the whole system and conditions.
The safety circuit of this controller is available in the system of category: up to 3, PL: up to d.

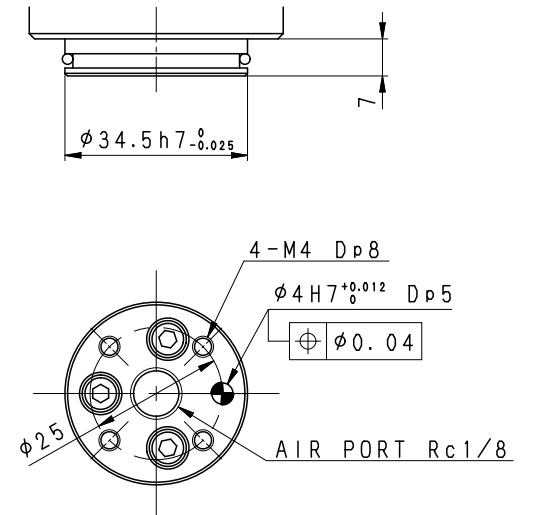
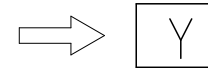
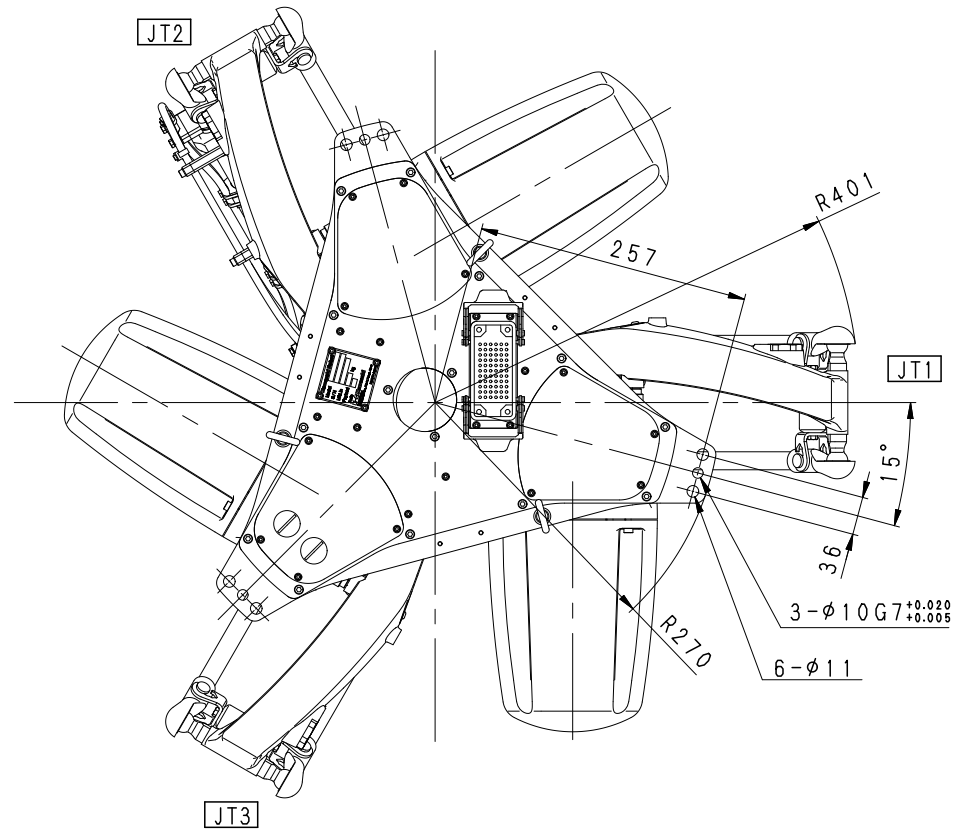

VIEW A

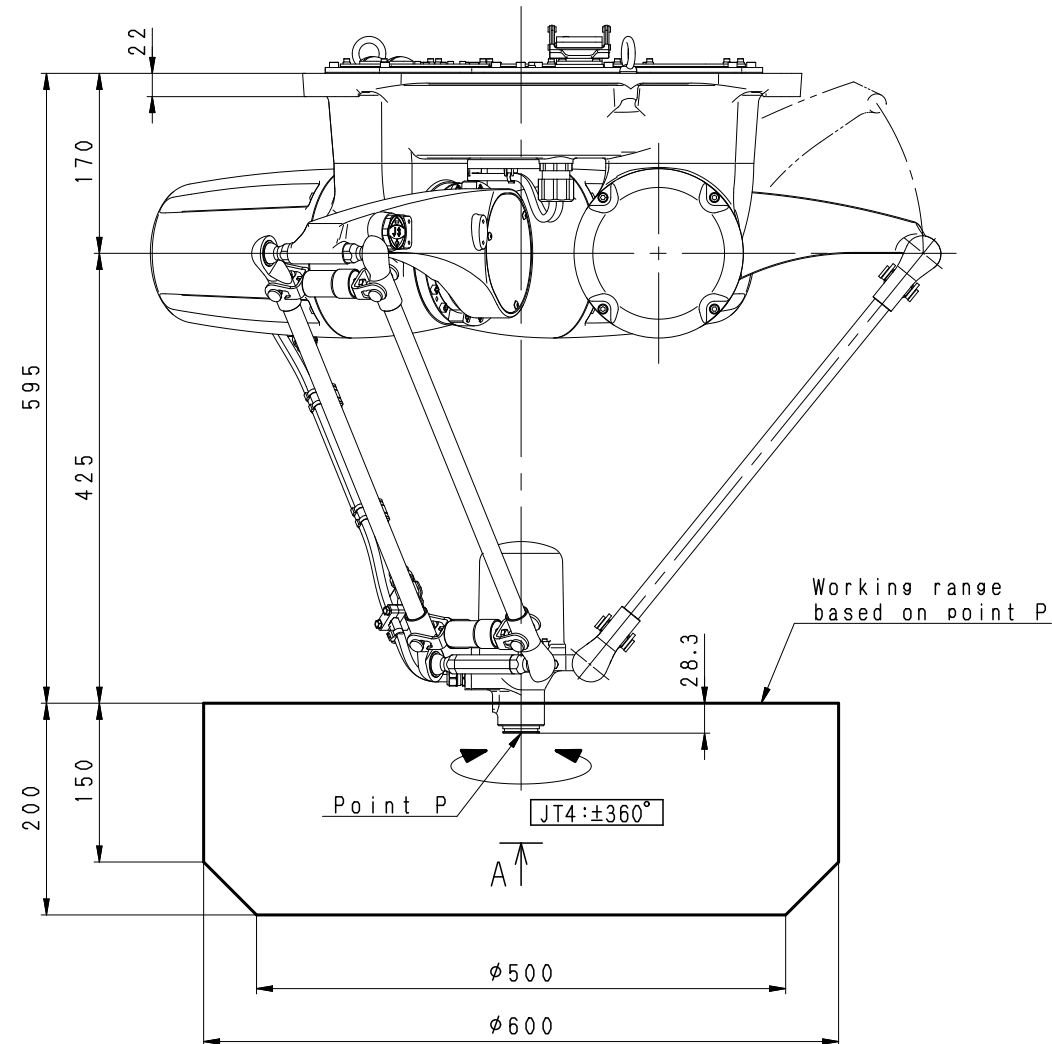
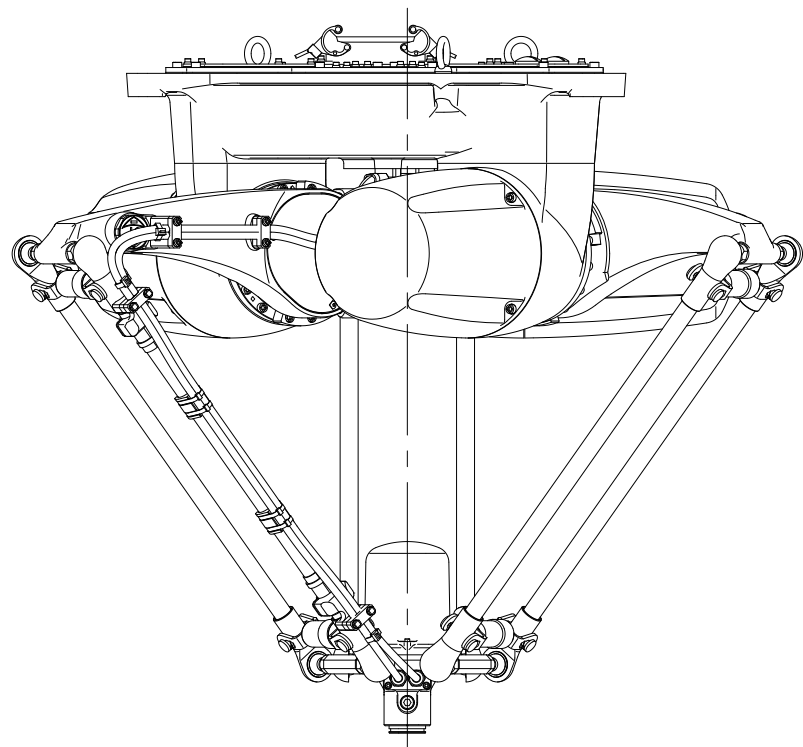

YF002N-C
WORKING RANGE

E 9 1 C O N T R O L L E R

M A S S : 4 0 K g

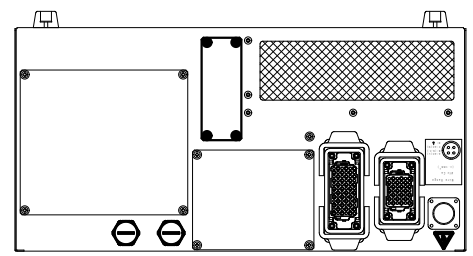

REAR VIEW

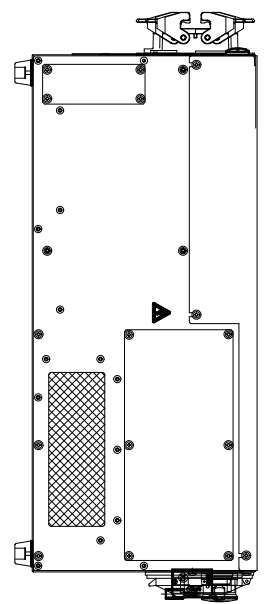

SIDE VIEW

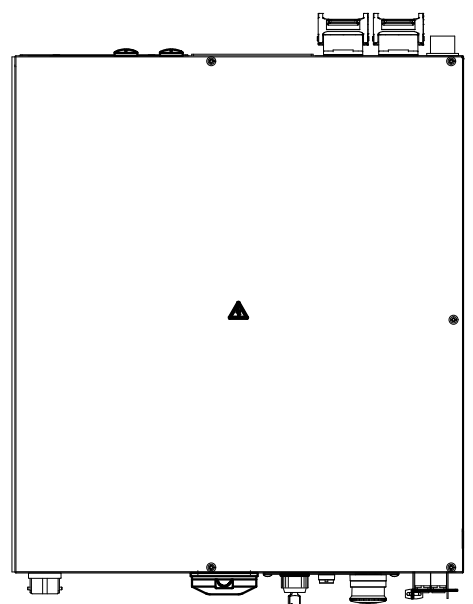

TOP VIEW

(50)
580
(34)

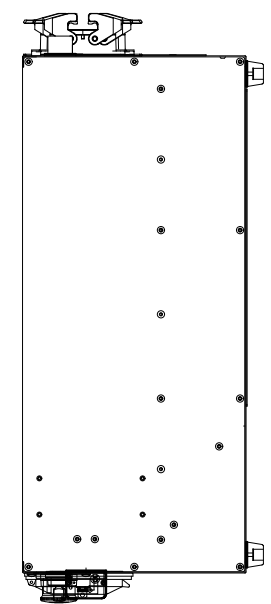

SIDE VIEW

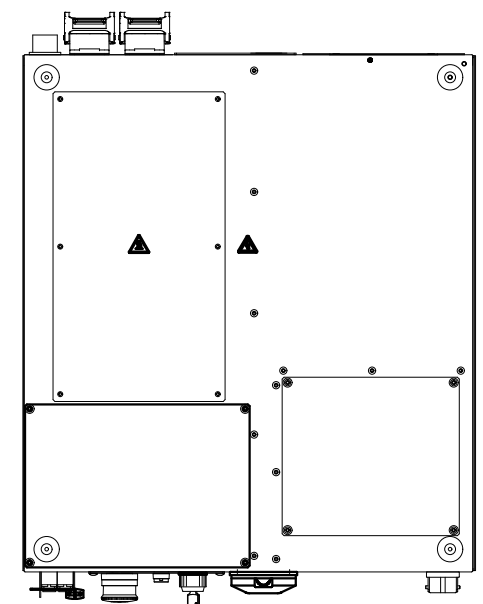

BOTTOM VIEW

Vertical Mount
縦置の場合

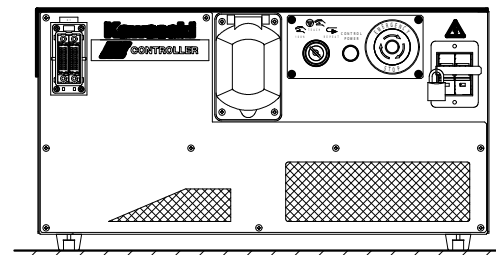
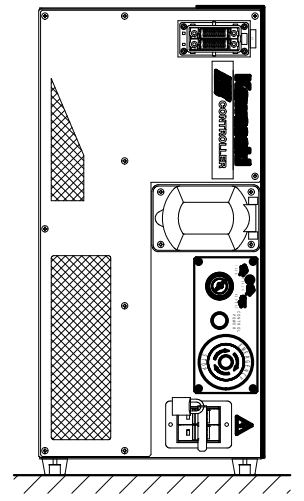

FRONT VIEW

500
250
18

